

NuDAQ[®]

PET-48DIO

**Programmable 48-bit DIO
Event, and Timer Cards
User's Guide**

@Copyright 1997~2000 ADLink Technology Inc.
All Rights Reserved.

Manual Rev. 3.20: November 22, 1999

The information in this document is subject to change without prior notice in order to improve reliability, design and function and does not represent a commitment on the part of the manufacturer.

In no event will the manufacturer be liable for direct, indirect, special, incidental, or consequential damages arising out of the use or inability to use the product or documentation, even if advised of the possibility of such damages.

This document contains proprietary information protected by copyright. All rights are reserved. No part of this manual may be reproduced by any mechanical, electronic, or other means in any form without prior written permission of the manufacturer.

Trademarks

NuDAQ[®], NuIPC[®], NuDAM[®], NuPRO[®] are registered trademarks of ADLink Technology Inc. Other product names mentioned herein are used for identification purposes only and may be trademarks and/or registered trademarks of their respective companies.

Contents

HOW TO USE THIS GUIDE	III
CHAPTER 1 INTRODUCTION	1
1.1 SPECIFICATIONS	1
1.2 APPLICATIONS	2
1.3 SOFTWARE SUPPORTING	3
1.3.1 <i>Programming Library</i>	3
1.3.2 <i>LabView Driver</i>	3
CHAPTER 2 INSTALLATION	5
2.1 WHAT YOU HAVE	5
2.2 UNPACKING	5
2.3 LAYOUT OF PET-48DIO	6
2.4 JUMPER AND DIP SWITCH DESCRIPTION	7
2.5 SETTING BASE ADDRESS	7
2.6 PULL-UP AND PULL-DOWN SETTING	9
2.7 OPTP-22 PIN-2 & PIN-4 CONFIGURATION SETTING	11
2.8 INTERRUPT IRQ LEVEL SETTING	12
2.9 TIMER & EVENT INTERRUPT SETTING	12
2.9.1 <i>Timer Interrupt Setting JP10</i>	13
2.9.2 <i>Event Counter Setting JP11</i>	13
2.9.3 <i>Timer Clock Source Setting JP12</i>	14
2.10 PROGRAMMABLE INTERRUPT SETTING	15
2.11 CONNECTORS	17
CHAPTER 3 CONTROL PROGRAMMING	21

3.1	PET-48DIO SOFTWARE LIBRARY INSTALLATION.....	21
3.2	8255 MODE 0	22
3.3	REGISTER STRUCTURE.....	23
3.4	PROGRAMMING FOR PET-48DIO	25
3.4.1	<i>Programming in Assembly Langrage.....</i>	<i>25</i>
3.4.2	<i>Programming in C language.....</i>	<i>30</i>
3.4.3	<i>A Complete Example Program for Interrupt Handling.....</i>	<i>33</i>
	PRODUCT WARRANTY/SERVICE	37

How to Use This Guide

This manual is designed to help you use the 7248/96 series products. It describes how to modify and control various functions on the cards to meet your requirements. It is divided into five chapters:

- Chapter 1, "Introduction," gives an overview of the product features, applications, and specifications.
- Chapter 2, "Installation," describes how to install the 7248/96 series products. The layout of are shown, the jumper settings, the connectors specifications, and the notes for installation are described.
- Chapter 3, "Register Structure & Format," describes the low-level register structure and format of the PCI-7224/7248/7296.
- Chapter 4, "Operation Theorem" describes more details about the versatile functions, including DIO, timer / counter, and interrupt systems.
- Chapter 5, "Software Library" specifies the software library of C language under DOS environment that makes you can operate the functions on this card easily.

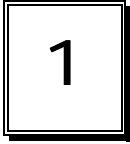

Introduction

The PET-48DIO is a digital input / output add-on card with 48 programmable I/O ports for IBM PC or compatibles. In addition to programmable I/O ports, an event counting and a timer pacer for interrupt are also included. The 48 programmable input / output ports are divided into two 24 programmable input / output ports for each group. Its pin assignment is fully compatible with opto-22 standard.

The features of the PET-48DIO include an event counter to count events that come from input port, a timer pacer for interrupt trigger, and four input ports can be as programmable real time interrupt source. These functionality make the PET-48DIO are very powerful to support complex digital I/O control applications.

Only two bytes of I/O address are occupied by PET-48DIO, it lets more cards can be installed in one system. All digital input / output ports are TTL compatible and use the 74LS244 as driver and buffer circuit to provide higher driving capacity for outputs and lower loading current for inputs than regular TTL circuit.

1.1 Specifications

◆ General Specification

- 48 programmable input / output ports
- High output driving capacity
- Low input loading
- One 16-bit programmable event counter
- One 32-bit programmable timer pacer

- Interrupt IRQ : IRQ3, ..., IRQ15 (9 levels jumper selectable)
- ◆ **Digital Input**
 - Logic level 0 : From -0.5 V to 0.8 V
 - Logic level 1 : From 2.0 V to 5.0 V
 - Input loading : 0.2 mA at 0.4 V
 - Input hysteresis : From 0.2 V to 0.4 V
 - Frequency Response: 500 KHZ
- ◆ **Digital Output**
 - Current sink of logic level 0 : 24 mA Max,
 - Current source of logic level 1 : 15 mA Max.
 - Driving capacity : 15 TTL's gate
 - Frequency Response: 500 KHZ
- ◆ **Programmable Event counter**
 - Frequency Response : DC to 2 MHZ
 - Counter ranger : From 1 to 65536
 - Trigger edge : Rising edge or falling edge
- ◆ **Programmable Timer Pacer**
 - Clock frequency : 32.768 KHZ or 2 MHZ
 - Frequency divider : Programmable
 - Counter : 32-bit (two 16-bit counters cascaded together)
- ◆ **Source of Interrupt**
 - Event counter count up
 - Timer time out
 - Input from ports

1.2 Applications

- **Digital Input**
 - . Contact closure monitoring
 - . Switch status monitoring
 - . BCD interface receiver
 - . Digital signal interface
- **Digital Output**
 - . Industrial ON / OFF control
 - . Digital signal interface
 - . BCD interface driver

1.3 Software Supporting

1.3.1 *Programming Library*

For the customers who are writing their own programs, we provide MS-DOS Borland C/C++ programming library which is included in the ADLink all-in-one CD.

ACLS-DLL1 is the Development Kit for NuDAQ ISA-Bus Cards with digital I/O, Windows 3.1/95/98/NT. ACLS-DLL1 can be used for many programming environments, such as VC++, VB, Delphi.

The ACLS-DLL1 included in the ADLink CD is 2-hour demo version, you can install it without series code and use it for 2 hours. Please contact with your dealer to purchase the formal version.

1.3.2 *LabView Driver*

The ACLS-LVIEW includes the PET-48DIO's, which is used to interface with NI's LabView software package. The ACLS-LVIEW supports Windows-95/98/NT.

2

Installation

This chapter describes how to install the PET-48DIO in your PC system.

2.1 What You Have

In addition to this *User's Manual*, the package includes the following items:

- PET-48DIO 48-bit DIO Event, and Timer Board
- ADLink All-in-one CD

If any of these items is missing or damaged, contact the dealer from whom you purchased the product. Save the shipping materials and carton in case you want to ship or store the product in the future.

2.2 Unpacking

Your PET-48DIO card contains sensitive electronic components that can be easily damaged by static electricity.

The card should be done on a grounded anti-static mat. The operator should be wearing an anti-static wristband, grounded at the same point as the anti-static mat.

Inspect the card module carton for obvious damage. Shipping and handling may cause damage to your module. Make sure there are no shipping and handling damages on the module before processing.

After opening the card module carton, extract the system module and place it only on a grounded anti-static surface component side up.

Again inspect the module for damage. Press down on all the socketed IC's to make sure that they are properly seated. Do this only with the module place on a firm flat surface.

Note: **DO NOT APPLY POWER TO THE CARD IF IT HAS BEEN DAMAGED.**

You are now ready to install your PET-48DIO.

2.3 Layout of PET-48DIO

This card has 14 jumpers, 2 connectors and 1 DIP switch, and their positions are shown in the figure 2.1 below.

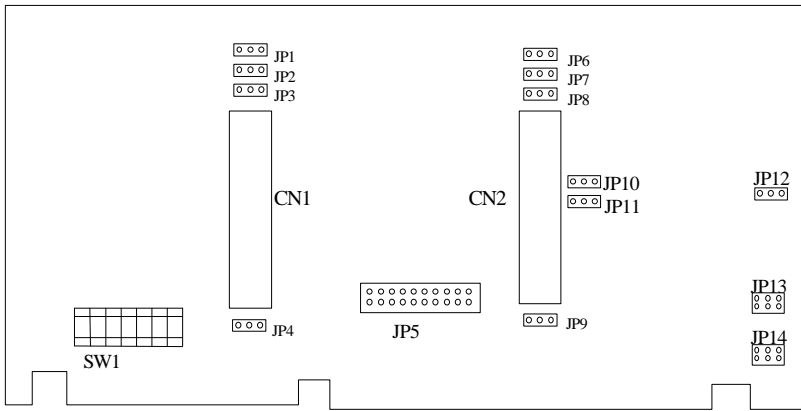

Fig 2.1 Layout of PET-48DIO

2.4 Jumper and DIP Switch Description

You can change the PET-48DIO channels and the base address by setting jumpers and DIP switches on the card. The card's jumpers and switches are preset at the factory. You can change the jumper settings for your own applications.

A jumper switch is closed (sometimes referred to as "shorted") with the plastic cap inserted over two pins of the jumper. A jumper is open with the plastic cap inserted over one or no pin(s) of the jumper.

2.5 Setting Base Address

You can change the PET-48DIO's I/O port address by setting Dual in Line Package switch (**SW1**) on the board. Under normal circumstances, you should not need to change the switch settings.

PET-48DIO requires two consecutive address locations in I/O address space. The base address of the PET-48DIO is restricted by the following conditions.

1. The base address must be within the range 000hex to 3FBhex.
2. The base address should not conflict with any PC reserved I/O address. see Appendix A.
3. The base address must not conflict with any add-on card on your own PC. Please check your PC before installing the PET-48DIO.

The PET-48DIO's I/O port base address is selectable by an 8 position DIP switch SW1. The default base address setting is **Hex 300** is illustrated as Figure 2.2 below. All possible base addresses for I/O port from Hex 000 to Hex 3FB are described in Table 2.1 on next page.

SW1 Default Base Address = 300H

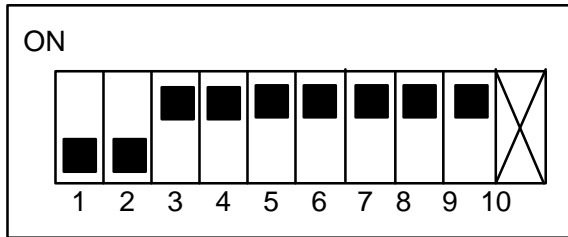

(A9 A8 A7 A6 A5 A4 A3 A2 A1)

Figure 2.2: Default Address Setting

I/O address setting shows as table below.

SW1-1 ----- SW1-9	SW 1-10
I / O based address setting	NC

Functionality of SW1

I/O port address(Hex)	1 A9	2 A8	3 A7	4 A6	5 A5	6 A4	7 A3	8 A2	9 A1
000-001	ON (0)	ON (0)	ON (0)	ON (0)	ON (0)	ON (0)	ON (0)	ON (0)	ON (0)
002-003	ON (0)	ON (0)	ON (0)	ON (0)	ON (0)	ON (0)	ON (0)	ON (0)	OFF (1)
004-005	ON (0)	ON (0)	ON (0)	ON (0)	ON (0)	ON (0)	ON (0)	OFF (1)	ON (0)
:									
300-301 (* default)	OFF (1)	OFF (1)	ON (0)	ON (0)	ON (0)	ON (0)	ON (0)	ON (0)	ON (0)
:									
3FC-3FD	OFF (1)	OFF (1)	OFF (1)	OFF (1)	OFF (1)	OFF (1)	OFF (1)	OFF (1)	ON (0)
3FE-3FF	OFF (1)	OFF (1)	OFF (1)	OFF (1)	OFF (1)	OFF (1)	OFF (1)	OFF (1)	OFF (1)

(*) : default setting

ON : 0 OFF : 1.

A1, ... A9 are correspond to PC address lines.

Table 2.1 I/O Base Address Table

2.6 Pull-Up and Pull-Down Setting

The input / output ports of PET-48DIO emulate as two Intel 8255 general purpose programmable peripheral interfaces(PPI). Figure 2.2 shows PET-DIO48's I/O ports equally block diagram.

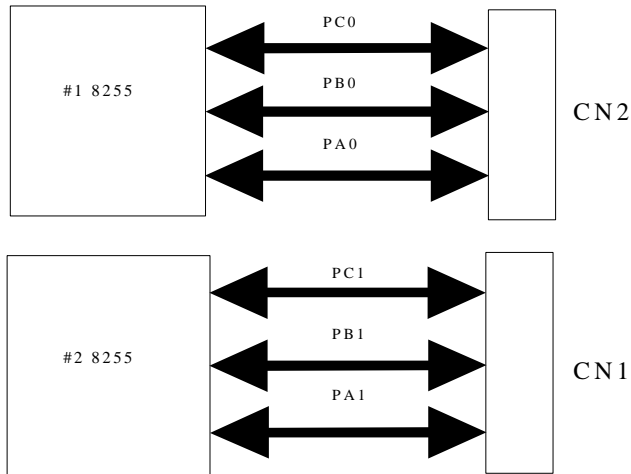

Figure 2.3 I / O port's block diagram

There are six build-in jumpers on PET-48DIO for pull up and pull down the I/O ports. The PET-48DIO can pull up PA, PB, PC to +5V, and pull down PA, PB, and PC to ground. A typical application where pull up resistors are used to monitor switch closure.

One network(Figure 2.4) is associated with each group of line. These networks can be quickly connected to a voltage source (pull up) or ground (pull down) through on board jumper setting.

The Pull-Up and Pull-Down configuration of each port is set by the jumper JP1, JP2, JP4, JP6, JP7, and JP9, respectively. The port configuration and its corresponding jumper are listed in below table.

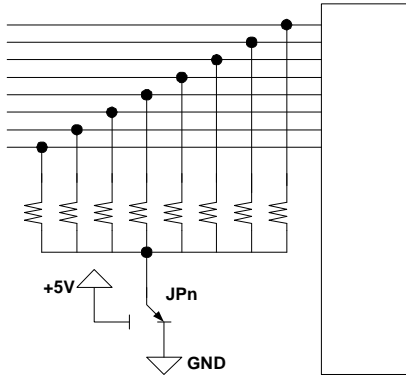
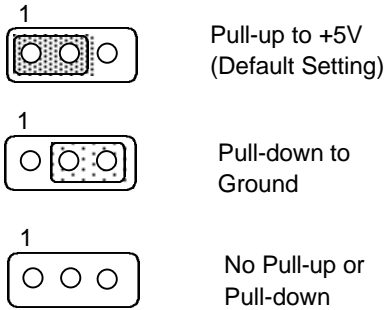

Figure 2.4 Pull-up/Pull-Down Network

Connector	I/O Port	Jumper
CN1	PB1	JP1
	PC1	JP2
	PA1	JP4
CN2	PB0	JP6
	PC0	JP7
	PA0	JP9

Table 2.2 Jumper for Pull-Up/Pull-Down Setting

(Jumper setting of for JP1, JP2, JP4, JP6, JP7, and JP9)



2.7 Optp-22 Pin-2 & Pin-4 Configuration Setting

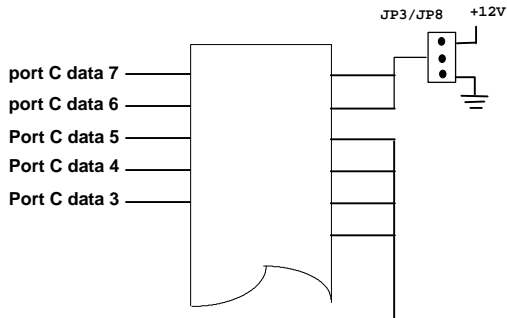
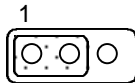

Figure 2.5 Connector of CN1 and CN2

The pin-2 and pin-4 of CN1 and CN2 can be configuration as +12V or Ground (GND). The JP3 and JP8 are used for the configuration of CN1 and CN2, respectively. The jumper settings are illustrated as below.

JP3 for CN1



Opto-22 Connector CN1
pin connect to +12V

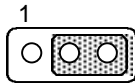

Opto-22 Connector CN1
pin connect to ground (default)

JP8 for CN2

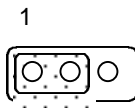

Opto-22 Connector CN2
pin connect to +12V

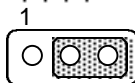

Opto-22 Connector CN2
pin connect to ground (default)

2.8 Interrupt IRQ Level Setting

The PET-48DIO can connect to any one of the interrupt lines of the PC I/O channel. The interrupt line is selected by the jumper **JP5**. If you wish to use the interrupt capability of the PET-48DIO, you must select an interrupt level and place the jumper in the appropriate position to enable the particular interrupt line.

The default interrupt level is **IRQ5**, which is selected by placing the jumper on the pins in row number 5. Figure 2.6 shows the default interrupt jumper setting IRQ5. You should only remove the jumper from IRQ5 to other pins, if you want to change to another IRQ level.

Note : Be aware that there is no other add-on card shares the same interrupt level at the same system.

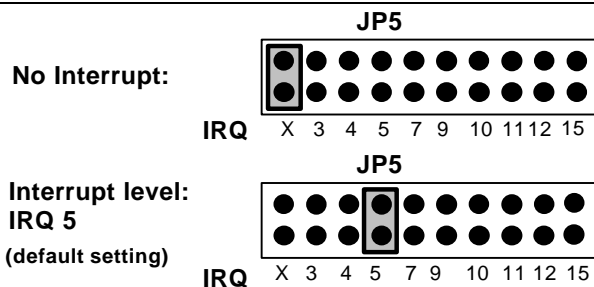

Figure 2.6 Default Interrupt Setting

2.9 Timer & Event Interrupt Setting

The PET-48DIO has an interval timer/counter 8253 on board. It offers 3 independent 16-bit programmable down counters; counter 1 and counter 2 are cascaded together for timer pacer trigger. and counter 0 is for event counting. Figure 2.7 shows the 8253 timer/counter connection.

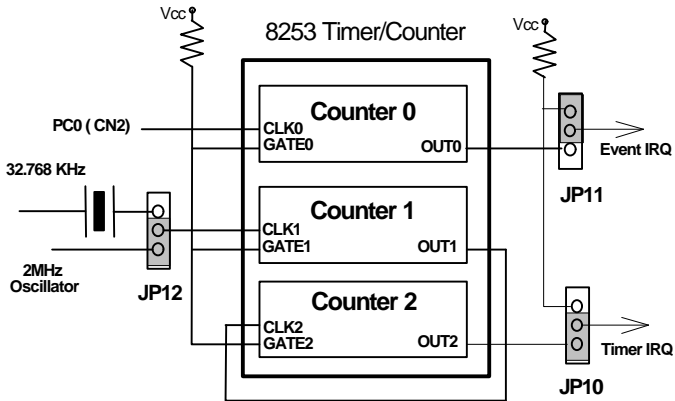
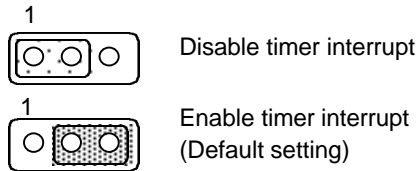

Figure 2.7 Block Diagram of 8253 Timer/Counter

2.9.1 Timer Interrupt Setting JP10

The jumper *JP10* is used for enabling or disabling timer interrupt, and the default jumper setting is illustrated as below.



2.9.2 Event Counter Setting JP11

The JP11 is for enabling or disabling event counter interrupt.

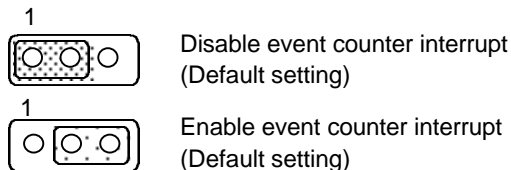

Note: PC0 D0 (first bit of PC0) is the input port of event counter.

2.9.3 Timer Clock Source Setting JP12

The JP12 is for select timer clock source. The range of timer is depend on clock source, PET-48DIO has two clock sources for timer, and setting range shows as table.

Clock source	Timer setting range
32.768 KHZ	0.000122 sec ~ 131072 sec
2 MHZ	0.000002 sec ~ 2147.4836 sec

The following equation is to calculate timer setting range.

$$\text{Timer range} = 1 / (\text{Timer Clock source} / (\text{Divide 1} * \text{Divide 2}))$$

Divide 1 is loading data of 8253 counter 1.

Divide 2 is loading data of 8253 counter 2.

For example:

Clock source is 32.768 KHZ. Set timer to 0.0122 Sec.

$$0.0122 = 1 / (32768 / (\text{Divide 1} * \text{Divide 2}))$$

$$(\text{Divide 1} * \text{Divide 2}) = 400$$

Let Divide 1=2 -> Hex0002 So Divide 2=200 -> Hex 00C8

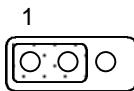

Select 32.768KHz

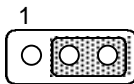

Select 2 MHz
(Default setting)

2.10 Programmable Interrupt Setting

The PC0D3 and PC0D7 are two real time interrupt input ports. JP13 is for PC0D3 and PC0D7 interrupt control setting.

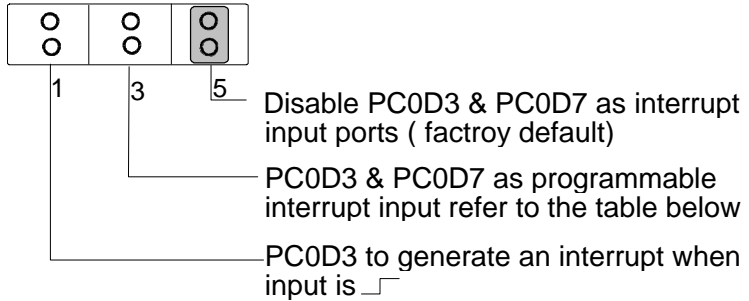

PC0D3	PC0D7	GENERATE AN INTERRUPT
RISING EDGE	0	YES
FALLING EDGE	0	NO
DON'T CARE	1	NO
0	DON'T CARE	NO
1	FALLING EDGE	YES
1	RISING EDGE	NO

PC0D3 & PC0D7 programmable interrupt table

The PC1D3 and PC1D7 are two real time interrupt input ports. JP14 is for PC1D3 and PC1D7 interrupt control setting, and the mini jumper is for setting.

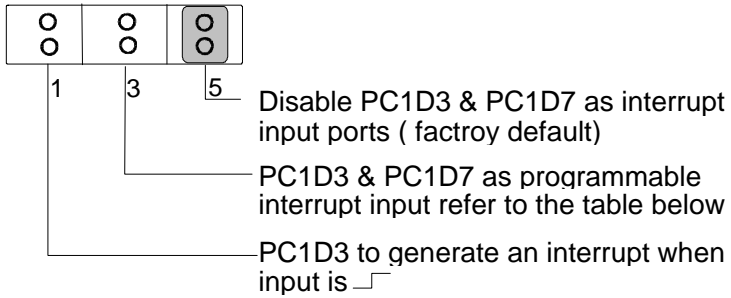

PC1D3	PC1D7	GENERATE AN INTERRUPT
RISING EDGE	0	YES
FALLING EDGE	0	NO
DON'T CARE	1	NO
0	DON'T CARE	NO
1	FALLING EDGE	YES
1	RISING EDGE	NO

PC1D3 & PC1D7 programmable interrupt table

2.11 Connectors

A 8255 has 24 I/O ports which may be individually programmed in 2 groups of 12 or 3 groups of 8. Figure shows PET-48DIO equally 8255-block diagram.

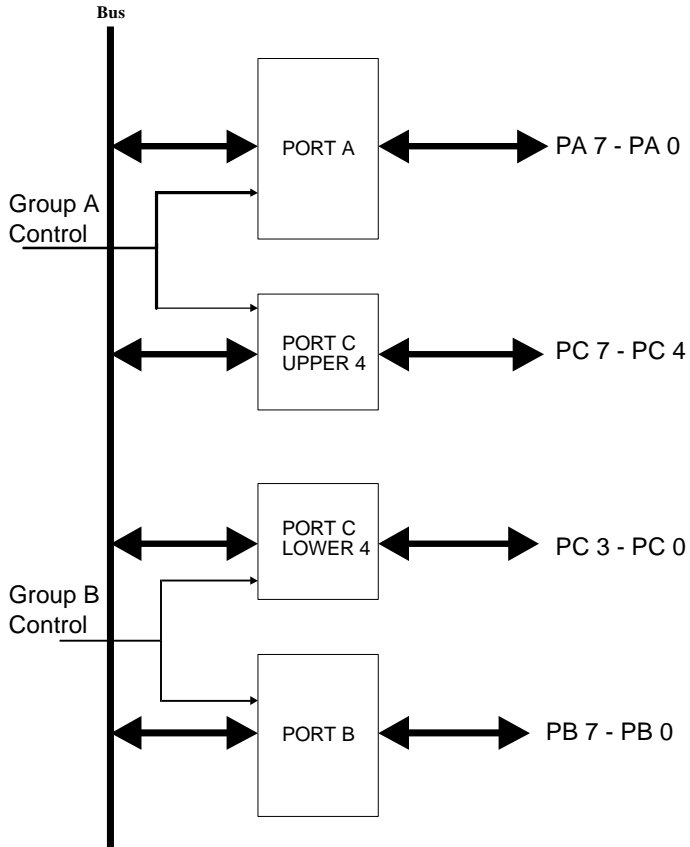
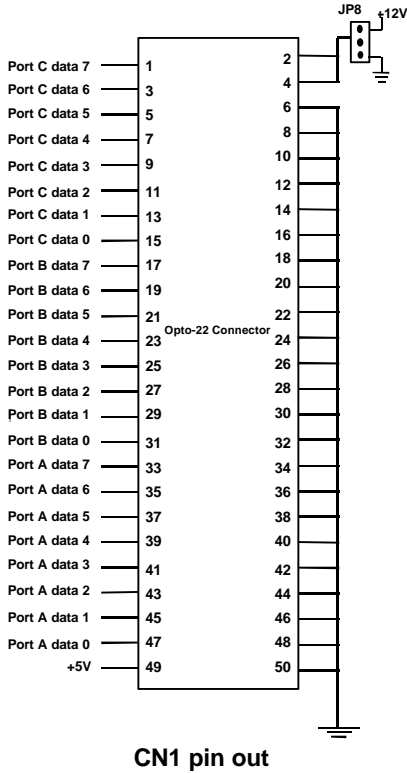

Figure 2.8 8255 block diagram

- **Pin Assignment of CN1**

The CN1 is a 50-pin connector for PA1, PB1, PC1 input / output ports connection, the pin out of CN1 is shown in the following figure:



- **Pin Assignment of CN2**

The CN2 is a 50-pin connector for PA0, PB0, PC0 input / output ports connecting, the pin out of CN2 is shown in the following figure.

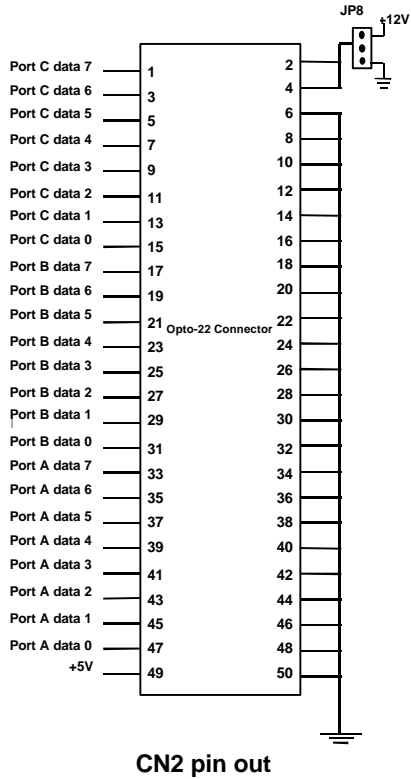

3

Control Programming

3.1 PET-48DIO Software Library Installation

The PET-48DIO's software library supplied with PET-48DIO includes the utility software, C-language library and some demonstration programs, which can help to reduce your programming effort.

1. Turn your PC's power switch on
2. Put the ADLink's "All-in-one" CD into the appropriate CD driver.
3. Type the commands(X indicates the CD ROM driver):

```
X:\> CD NuDAQISA\48DIO  
X:\NuDAQISA\48DIO> SETUP
```
4. An installation completed message will be shown on the screen.

After installation, all the files of *PET-48DIO Library & Utility for DOS* are stored in C:\ADLink\48DIO\DOS directory.

3.2 8255 Mode 0

The PET-48DIO can emulate MODE 0 of 8255 PPI, and it comes equipped with two 50-pin male IDC connectors that interface with OPTO-22 racks 8, 16, and 24.

The basic function definition of 8255 mode 0 is :

- . Two 8-bit I/O ports - PA and PB
- . Two nibble-wide (4-bit) ports - PC upper and PC lower
- . Any ports can be used for both input and output
- . Outputs are latched whereas inputs are not latched
- . 16 different input/output configurations are available

PC0 is used to generate a hardware interrupt, and PC4 is used to control programmable interrupt.

The I / O of PET-48DIO emulates as one 8255 programmable peripheral interface chip, the *control word* is to program PA, PB and PC as input port or output port. Table shows the summarize of control word (D0 - D4), and mode states (Mode 0 - Mode 15) .

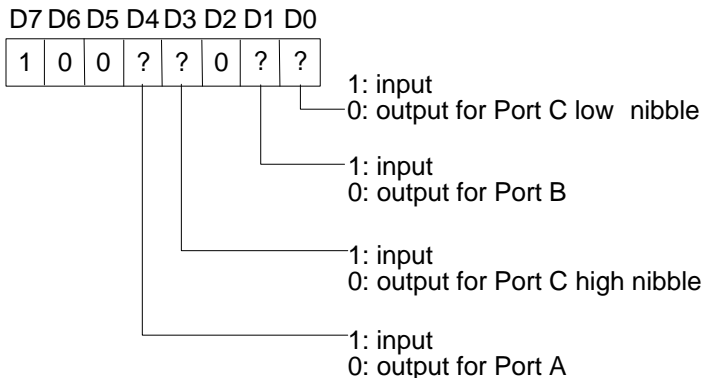

Config. Value	D4	D3	D1	D0	PORTA	PORT C UPPER	PORTB	PORT C LOWER
80H	0	0	0	0	O/P	O/P	O/P	O/P
81H	0	0	0	1	O/P	O/P	O/P	I/P
82H	0	0	1	0	O/P	O/P	I/P	O/P
83H	0	0	1	1	O/P	O/P	I/P	I/P
88H	0	1	0	0	O/P	I/P	O/P	O/P
89H	0	1	0	1	O/P	I/P	O/P	I/P
8AH	0	1	1	0	O/P	I/P	I/P	O/P
8BH	0	1	1	1	O/P	I/P	I/P	I/P
90H	1	0	0	0	I/P	O/P	O/P	O/P
91H	1	0	0	1	I/P	O/P	O/P	I/P
92H	1	0	1	0	I/P	O/P	I/P	O/P
93H	1	0	1	1	I/P	O/P	I/P	I/P
98H	1	1	0	0	I/P	I/P	O/P	O/P
99H	1	1	0	1	I/P	I/P	O/P	I/P
9AH	1	1	1	0	I/P	I/P	I/P	O/P
9BH	1	1	1	1	I/P	I/P	I/P	I/P

Table 3.1 Summarize of control word (D0 - D4) and mode state (Mode 0 - Mode 15)

3.3 Register Structure

The PET-48DIO needs two bytes of I / O address to operate, the first byte is ports' ***index select*** and the second byte is ports' ***data read/write***.

Index Select : The register is used to define the index of I/O ports. You have to define this value before you read or write data to the I/O port of PET-48DIO. Please refer the I/O port's index values in table 3.2.

Data Read/Write : This register is used to read or write data to the correspond I/O port which you have defined in the ***Index Select*** register.

For example, If you defined the PET-48DIO's I/O port address as 300H, then the *index select register is 300H*, and *Data Read/Write register is 301H*.

The relationship of ports' index select and ports' data read / write shows as figure.

The following table is ports' index that set by first I/O address.

PORT SELECT	INDEX	Description
GROUP #0 PA0	0H	EMULATE AS 8255 PA
GROUP #0 PB0	1H	EMULATE AS 8255 PB
GROUP #0 PC0	2H	EMULATE AS 8255 PC
CONTROL WORD of GROUP #0	3H	EMULATE AS 8255 CW
GROUP #1 PA1	4H	EMULATE AS 8255 PA
GROUP #1 PB1	5H	EMULATE AS 8255 PB
GROUP #1 PC1	6H	EMULATE AS 8255 PC
CONTROL WORD of GROUP #1	7H	EMULATE AS 8255 CW
COUNT1 OF 8253	80H	EVENT COUNTER
TIMER 1 OF 8253	81H	TIMER1 CASCADE WITH TIMER2
TIMER 2 OF 8253	82H	TIMER2 CASCADE WITH TIMER1
8253 CONTROL WORD	83H	Control Word for 8253

Table 3.2 Ports' index table

3.4 Programming for PET-48DIO

According to the description of above sections, you can understand how to program the PET-48DIO easily. Partial of Assembly and C programs will be listed below, and a complete C source program for timer pacer interrupt of PET-48DIO is included.

If you need more high level Application Programming Interface (API) library in C Language, you can get it from our software package ACLS-DLL1. Both Windows DLL driver and DOS software driver of the PET-48DIO will be included in the ACLS-DLL1. Please contact your dealer of ADLink products.

3.4.1 *Programming in Assembly Language*

The following parts are example programs written in assemble for reference.

Programming in assemble

The following parts are example programs written by assemble for reference.

To initial I/O ports

```
MOV     DX , INDEX      ; DATA OF INDEX SAME AS I/O
                          ; ADDRESS THAT SET BY SW1
MOV     AL , CTRL0      ; CTRL0 = 3H
OUT     DX , AL         ; INDEX TO GROUP 0 CONTROL
                          ; WORD
JMP     $+2             ; DELAY
INC     DX              ; POINT TO DATA READ/WRITE
                          ; ADDRESS
MOV     AL , CW50       ; CONTROL WORD REFER TO
                          ; TABLE OF CONTROL WORD
OUT     DX , AL         ; PROGRAM GROUP 0 I/O
JMP     $+2             ; DELAY
DEC     DX              ; POINT TO INDEX ADDRESS
MOV     AL , CTRL1      ; CTRL1 = 7H
```

```

OUT      DX , AL      ; INDEX TO GROUP 1 CONTROL
                        ; WORD
JMP      $+2          ; DELAY
INC      DX           ; POINT TO DATA READ/WRITE
                        ; ADDRESS
MOV      AL , CW51    ; CONTROL WORD REFER TO
                        ;TABLE OF CONTROL WORD
OUT      DX , AL      ; PROGRAM GROUP 1 I/O
JMP      $+2

```

To write the port

```

MOV      DX , INDEX   ; DATA OF INDEX SAME AS I /O
                        ; ADDRESS THAT SET BY SW1
MOV      AL , CTRL0   ; CTRL0 = 3H
OUT      DX , AL      ; SET INDEX TO GROUP 0
                        ; CONTROL WORD
JMP      $+2          ; DELAY
MOV      DX , DATA   ; DATA = INDEX + 1
MOV      AL , MOD0    ; 8255 MODE 0 = 0
OUT      DX , AL      ; WRITE MOD0 TO CTRL0
JMP      $+2          ; DELAY
DEC      DX           ; POINT TO INDEX ADDRESS
MOV      AL , PA0     ; PA0 = 0
OUT      DX , AL      ; INDEX TO PA0
JMP      $+2          ; DELAY
INC      DX           ; POINT TO DATA READ/WRITE
                        ; ADDRESS
MOV      AL , 55H     ;
OUT      DX , AL      ; WRITE 55H TO PA0
JMP      $+2
DEC      DX           ;

```

To access the port

```

MOV      DX , INDEX   ; DATA OF INDEX SAME AS I/O
                        ; ADDRESS THAT SET BY SW1
MOV      AL , CTRL1   ; CTRL1= 7H

```

```

OUT     DX , AL      ; INDEX TO GROUP1 CONTROL
        ; WORD
JMP     $+2          ; DELAY
INC     DX           ; POINT TO DATA READ/WRITE
        ; ADDRESS
MOV     AL , MODE15  ; MODE15 = 17H
OUT     DX , AL      ; WRITE MODE15 TO CTRL1
JMP     $+2          ; DELAY
DEC     DX           ; POINT TO INDEX ADDRESS
MOV     AL , PA1     ; PA1 = 4H
OUT     DX , AL      ; INDEX TO PA1
JMP     $+2          ; DELAY
INC     DX           ; POINT TO DATA READ/WRITE
        ; ADDRESS
INAL   , DX         ; READ PA1
JMP     $+2

```

To initial 8253

```

MOV     DX , INDEX   ; DATA OF INDEX SAME AS I/O
        ; ADDRESS THAT SET BY SW1
MOV     AL , CTRL53  ; CTRL53 = 83H
OUT     DX , AL      ; SET INDEX TO 8253 CONTROL
        ; WORD
JMP     $+2          ; DELAY
INC     DX           ; POINT TO DATA READ/WRITE
        ; ADDRESS
MOV     AL , CW0     ; CW0 = 00110000B
OUT     DX , AL      ; 8253 COUNT 0 AS MODE 0:
        ; INTERRUPT ON TERMINAL
        ; COUNT
JMP     $+2          ; DELAY
MOV     AL , CW1     ; CW1 = 01110100B
OUT     DX , AL      ; 8253 COUNT 1 AS MODE 2:
        ; RATE GENERATOR
JMP     $+2          ; DELAY
MOV     AL , CW2     ; CW2 = 10110000B

```

```

OUT      DX , AL      ; 8253 COUNT 2 AS MODE 0:
          ; INTERRUPT ON TERMINAL
          ; COUNT
JMP      $+2          ; DELAY

```

To set event counter

```

MOV      DX , INDEX   ; DATA OF INDEX SAME AS I/O
          ; ADDRESS THAT SET BY SW1
MOV      AL , C530    ; C530 = 80H
OUT      DX , AL      ; INDEX TO COUNT 0
JMP      $+2          ; DELAY
INC      DX           ; POINT TO DATA READ/WRITE
          ; ADDRESS
MOV      AL , 32H     ; LOAD LEAST BYTE 32H
OUT      DX , AL      ; LOAD LEAST BYTE
JMP      $+2          ; DELAY
MOV      AL , 00H     ; LOAD MOST BYTE 00H
OUT      DX , AL      ; LOAD MOST BYTE
JMP      $+2

```

To set timer

```

MOV      DX , INDEX   ; DATA OF INDEX SAME AS I/O
          ; ADDRESS THAT SET BY SW1
MOV      AL , C531    ; C531 = 81H
OUT      DX , AL      ; INDEX TO COUNT 1
JMP      $+2          ; DELAY
INC      DX           ; POINT TO DATA READ/WRITE
          ; ADDRESS
MOV      AL , 30H     ; LOAD LEAST BYTE 30H
OUT      DX , AL      ; LOAD LEAST BYTE
JMP      $+2          ; DELAY
MOV      AL , 10H     ; LOAD MOST BYTE 10H
OUT      DX , AL      ; LOAD MOST BYTE
JMP      $+2          ; DELAY
DEC      DX           ; POINT TO INDEX ADDRESS
MOV      AL , C532    ; C532 = 82H
OUT      DX , AL      ; INDEX TO COUNT 2

```

```

JMP     $+2           ; DELAY
INC     DX            ; POINT TO DATA READ/WRITE
                    ; ADDRESS
MOV     AL , 10H      ; LOAD LEAST BYTE 10H
OUT     DX , AL       ; LOAD LEAST BYTE
JMP     $+2           ; DELAY
MOV     AL , 00H      ; LOAD MOST BYTE 00H
OUT     DX , AL       ; LOAD MOST BYTE
JMP     $+2           ; DELAY

```

To clear and enable interrupt

```

MOV     DX , INDEX    ; DATA OF INDEX SAME AS I/O
                    ; ADDRESS THAT SET BY SW1
MOV     AL , CTRL0    ; CTRL0 = 3H
OUT     DX , AL       ; SET INDEX TO GROUP 1 8255
                    ; CONTROL WORD
JMP     $+2           ; DELAY
INC     DX            ; POINT TO DATA READ/WRITE
                    ; ADDRESS
IN      AL , DX       ; DUMMY READ TO CLEAR
                    ; AND ENABLE INTERRUPT

```

3.4.2 Programming in C language

The following parts are example programs written in C language for reference.

Note : These softwares are only partial of complete program, so you can not execute them directly.

To initial I/O port

```
# define INDEX 0x300 //define same as
                        //address setting
# define DATA 0x301 //data R/W port
# define CW0 0x3 //port 0 control port
# define CW1 0x7 //port 1 control port
# define CWD0 0x0A //0AH refer to 8255 CW
                        //Mode6 Port A & B output,
                        // Port C input
# define CWD1 0x0B //0BH refer to 8255 CW
                        //Mode7 Port A output,
                        // Port B & C input
outportb( INDEX,CW0); //point to port0's control word
outportb( DATA,CWD0); //initial port0
outportb( INDEX,CW1); //point to port1's control word
outportb( DATA,CWD1); //initial port 1
```

To write port

```
# define INDEX 0x300 //INDEX same as SW
                        //setting
# define DATA 0x301 //data R/W port
# define CW1 0x3 //port 0 CW
# define MOD0 0x0 //8255 mode 0 Port A, B &
C
                        // are output port
#define PA0 0x0 //port A0
#define PB0 0x1 //port B0

outportb(INDEX,CW0); //index to port0 CW
```

```

outportb(DATA,MOD0); //initial port0 as
                    //mod 0 for output
outportb(INDEX,PA0); //index to port A0
outportb(DATA,0x55); //output 55H
outportb(INDEX,PB0); //index to port B0
outportb(DATA, 0xFF); //output FFH to Port B0

```

To access port

```

# define INDEX 0x300 //INDEX same as SW
                    //setting
# define DATA 0x301 //data R/W port
# define MOD15 0x17 //8255 mode 15
# define PA1 0x4 //PA1 port index
# define CW1 0x7 //port 1 CW

int input; //input data buffer
outportb(INDEX,CW1); //index to port 1 CW
outportb(DATA,MOD15); //initial port 1 as mod
                    //15 for input
outportb(INDEX,PA1); //index to port A 1
input = inportb(DATA); //read PA1

```

To initial 8253

```

# define INDEX 0x300 //INDEX same as SW
                    //setting
# define DATA 0x301 //data R/W port
# define CW53 0x83 //8253 control port
# define CWD531 0x30 //8253 counter 1 CW
# define CWD532 0x74 //8253 control 2 CW
# define CWD533 0xB0 //8253 control 3 CW
outportb(INDEX,CW53); //index to 8253 control
                    //port
outportb(DATA,CWD531); //initial counter 1
outportb(DATA,CWD532); //initial counter 2
outportb(DATA,CWD533); //initial counter 3

```

To set event counter

```
# define INDEX 0x300 //INDEX same as SW
//setting
# define DATA 0x301 //data R/W port
# define CW530 0x80 //event counter index
outportb(INDEX,CW530); //index to counter 1
outportb(DATA,0x32); //write 32H to low byte
outportb(DATA,0x0); //write 0H to high byte
```

To set timer

```
# define INDEX 0x300 //INDEX same as SW
//setting
# define DATA 0x301 //data R/W port
# define CW531 0x81 //timer 1 index
# define CW532 0x82 //timer 2 index
outportb(INDEX,CW531); //index to timer 1
outportb(DATA,0x30); //write 30H to timer 1
//low byte
outportb(DATA,0x10); //write 10H to timer 1
//high byte
outportb(INDEX,CW532); //index to timer 2
outportb(DATA,0x10); //write 10H to timer 2
//low byte
outportb(DATA,0x00); //write 00H to timer 2
//high byte
```

3.4.3 A Complete Example Program for Interrupt Handling

```

/*****
****/
/*          File   name   :                test.C
*/
/*      Purpose  :                PET-48DIO TEST   Source Code
*/
/*          Date   :                06/02/1994
*/
/*          Version :                1.0
*/
/*          Programmer :                JIM   LIU
*/
/* Configuration : (jumper settings)                */
/*      JP5   : IRQ5                */
/*      JP10  : 1-2 ( Disable)        */
/*      JP11  : 2-3 ( Enable)        */
/*      JP13  : 5-6 ( Disable)        */
/*      JP14  : 5-6 ( Disable)        */
/*
*/
/*      Copyright ACLONE Inc. (c) 1994   all right
reserved */
/*****
****/
#include <dos.h>
#include <conio.h>

/*****/
/* Constants Decalarations                */
/*****/

#define      LOBYTE(arg)      (*(unsigned char *)&arg)
#define      HIBYTE(arg)      (*((unsigned char *)&arg +
1))
#define      LOWORD(arg)      (*(unsigned int *)&arg)

```

```

#define      HIWORD(arg)      (*((unsigned int *)&arg +
1))

/***** Define Relative Addresses *****/
#define      CCW              0x83
#define      COUNT            0x80
#define      TIMER1           0x81
#define      TIMER2           0x82
#define      PA0              0x0
#define      PB0              0x1
#define      PC0              0x2
#define      CW0              0x3
#define      PA1              0x4
#define      PB1              0x5
#define      PC1              0x6
#define      CW1              0x7

/*----- Define 8259 -----
-*/
#define      IC8259_1         0x20
#define      IC8259_2         0xA0
#define      EOI              0x20

/*-----
--*/
#define      NO_INIT          0xff
#define      INITIALED        0x00
#define      IRQ5             0x0d
#define      INDEX            0x300
#define      DATA            0x301

void      interrupt      far do_isr(void);
void      interrupt      (*old_isr)(void);

int      Base_addr;
int      inter = 0;

```

```

/*-----
---*/
void set_counter( unsigned char c)
{
    outp( INDEX, CCW);
    outp( DATA, 0x30);
    outp( INDEX, COUNT);
    outp( DATA, c);
    outp( DATA, 0x00);
}
unsigned char ia = 0x2;
void interrupt far do_isr()
{
    outp( INDEX, PA0);
    outp( DATA, ia);
    if( ia > 0xbe) ia = 0x0;
    ia = ia + 5;
    inter = 1;
    outp( INDEX, 0x3);
    inp( DATA);
    outp( IC8259_1, 0x20);
}

/* Timer pacer interval is depend on the value of c1 and
c2*/
void set_timer( int c1, int c2)
{
    outp( INDEX, CCW);
    outp( DATA, 0x76);
    outp( DATA, 0xb6);
    outp( INDEX, TIMER1);
    outp( DATA, LOBYTE(c1));
    outp( DATA, HIBYTE(c1));
    outp( INDEX, TIMER2);
    outp( DATA, LOBYTE(c2));
    outp( DATA, HIBYTE(c2));
}
main()
{

```

```

unsigned char  vb = 0;
unsigned char  vc;
clrscr();
/* enable and clear interrupt */
outp( INDEX, 0x3);
inp( DATA);
old_isr = getvect( IRQ5);
setvect( IRQ5, do_isr);
outp( IC8259_1 + 1, ( inp( 0x21) & 0xdf));

outp( INDEX, CW0);
outp( DATA, 0x09); /* mode 5 : PA0, PB0 are output
*/
set_timer(1400,2400);
do
{
    if( inter == 1)
    {
        outp( INDEX, 0x03);
        inp( DATA);
        printf( " interrupt \n");
        inter = 0;
    }
}while( kbhit() == 0);
setvect( 0x0d, old_isr);
outp( 0x21, 0xb8);
return( 0);
}

```

Product Warranty/Service

Seller warrants that equipment furnished will be free from defects in material and workmanship for a period of one year from the confirmed date of purchase of the original buyer and that upon written notice of any such defect, Seller will, at its option, repair or replace the defective item under the terms of this warranty, subject to the provisions and specific exclusions listed herein.

This warranty shall not apply to equipment that has been previously repaired or altered outside our plant in any way as to, in the judgment of the manufacturer, affect its reliability. Nor will it apply if the equipment has been used in a manner exceeding its specifications or if the serial number has been removed.

Seller does not assume any liability for consequential damages as a result from our products use, and in any event our liability shall not exceed the original selling price of the equipment.

The equipment warranty shall constitute the sole and exclusive remedy of any Buyer of Seller equipment and the sole and exclusive liability of the Seller, its successors or assigns, in connection with equipment purchased and in lieu of all other warranties expressed implied or statutory, including, but not limited to, any implied warranty of merchant ability or fitness and all other obligations or liabilities of seller, its successors or assigns.

The equipment must be returned postage-prepaid. Package it securely and insure it. You will be charged for parts and labor if you lack proof of date of purchase, or if the warranty period is expired.